

# INSTALLATION INSTRUCTIONS

## HC6000 DC Hi-Lo DC Pump Controller

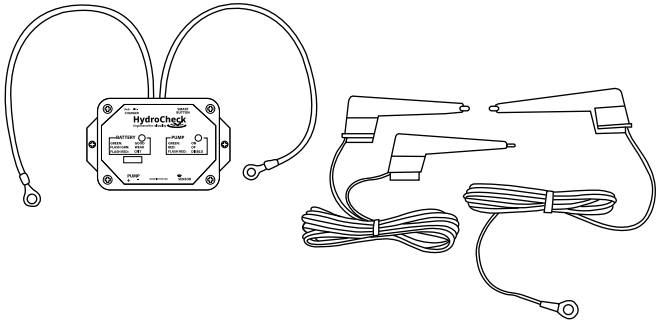

### What comes in the box

This product does not include the following components necessary for a backup system set up:

- Pump (Max. 12 Amps at 12 VDC)
- Battery
- Battery charger
- Battery box
- Check valve
- Piping

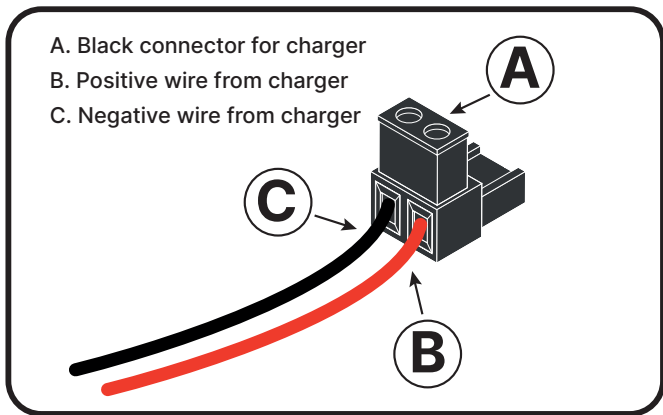

### Step 1. Prepare Pump Connector

- Identify positive and negative conductors. Usually, positive conductor is brown in color and/or tagged with “+” flag, and negative conductor is black
- Strip ¼” insulation off each conductor
- Insert conductors and secure by tightening screws. Tug on each wire to make sure it is secure and does not pull out. Also, ensure that there are no loose wire strands that might cause a short.
- Pay close attention to which opening the wires are inserted into. If installed backwards the pump will run in reverse and may damage it.

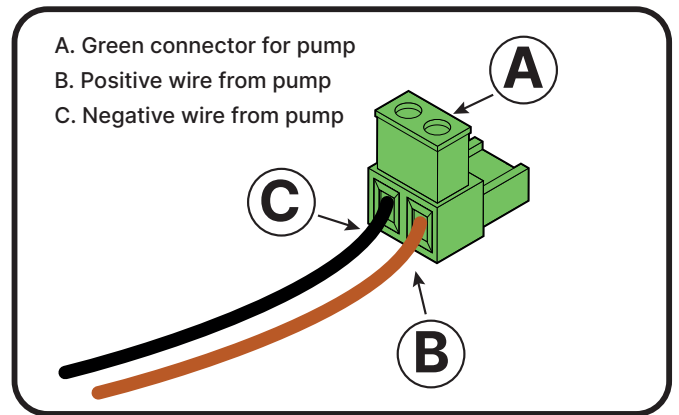

### Step 2. Prepare Battery Charger Connector

- Identify positive and negative conductors. Usually, the positive conductor is red in color and/or tagged with “+” flag, and the negative conductor is black
- Remove the battery clamps from the end of the positive and negative cables.
- Strip ¼” insulation off each conductor
- Insert conductors and secure by tightening screws. Tug on each wire to make sure it is secure and does not pull out. Also, ensure that there are no loose wire strands that might cause a short
- Pay close attention to which opening the wires are inserted into. If installed backwards the battery will not charge and the charger may be damaged.

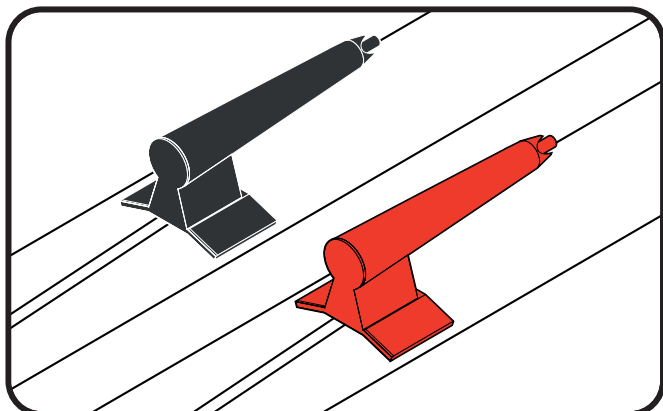

### Step 3. Install Sensors

- Using a tie-wrap, secure the **RED SENSOR** to the backup pump’s discharge pipe where the pump is intended to turn on. (NOTE: Sensor placement should be above where the primary pump turns on).
- Use another tie-wrap to secure the **BLACK SENSOR** to the backup pump’s discharge at the level where the pump should be turned off. Make sure that pump is capable of pumping the water below the tip of the sensor.
- Use a tie-wrap to secure the **GROUND SENSOR** to the pump’s discharge pipe. Make sure the tip of the sensor is below the tip of the **BLACK SENSOR**.

Buzzer	
3 Beeps & Pause	Water level not dropping
2 Beeps & Pause	Pump activated
Rapid, Steady, Beep	Battery charges is critical
Slow, Steady, Beep	Battery charges is getting weak

**Note:** Pressing the Smart Button silences the alarm for 24 hours.

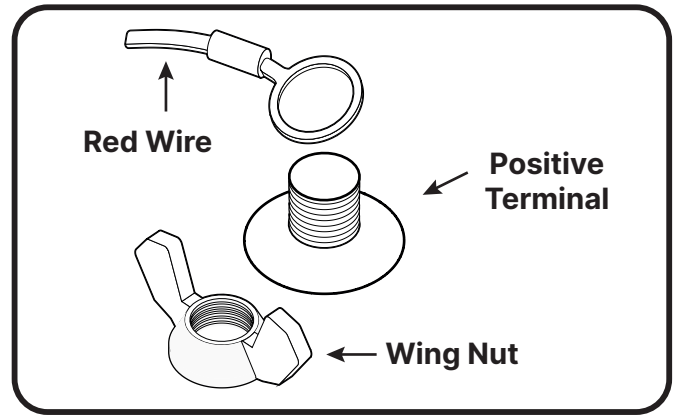
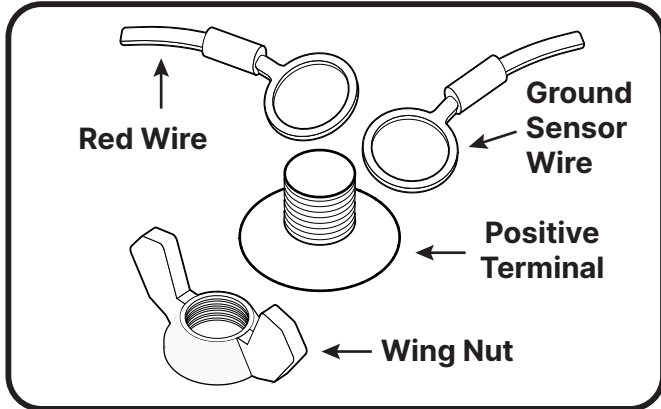

#### Step 4. Connect Red Wire with Ring Terminal to Battery

Secure the red conductor from the HC6000-DC to the positive (+) battery terminal using the wingnut supplied with the battery.

#### Step 5. Connect Black Wire with Ring Terminal and Ground Sensor with Ring terminal to Battery

Secure the black conductor from the HC6000-DC and the **GROUND SENSOR** cable to the negative (-) battery terminal using the wingnut supplied with the battery.

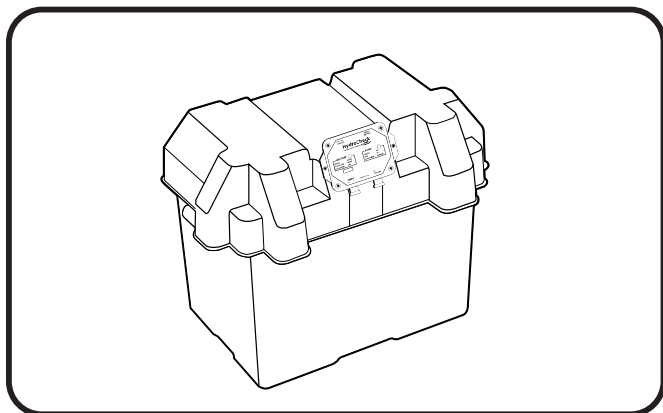

#### Step 6. Secure HC6000-DC to Battery Enclosure

Secure the control box to the lid of the battery case using the supplied self tapping screws.

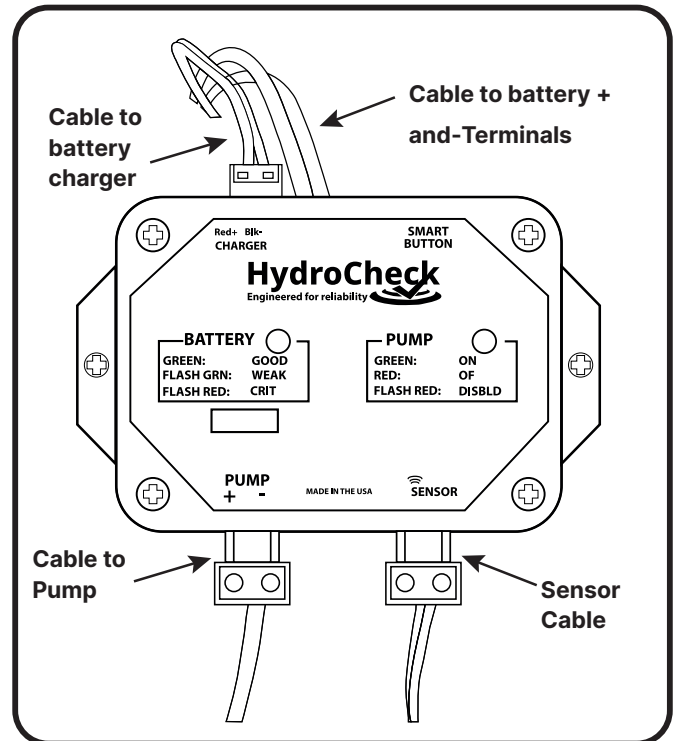

#### Step 7. Plug in Connectors

- Plug the Pump, Sensor and Battery Charger connectors to the control box

Battery LED	
Steady Green	Battery charge is good
Flashing Green	Battery charge is getting weak
Flashing Red	Battery voltage is critically low. Pump is disabled.

Pump LED	
Steady Green	Pump is running
Steady Red	Pump off
Flashing Red	Pump is disabled because battery charge is too low.